

TUTORIAL SHEET 2B: BENDING OF BEAMS

1. A box beam is constructed from four pieces of wood, glued together as shown. If the moment acting on the cross section is $10 \text{ kN}\cdot\text{m}$, determine the stress at points A and B. $[\sigma_A = -6.21 \text{ MPa}, \sigma_B = 5.17 \text{ MPa}]$

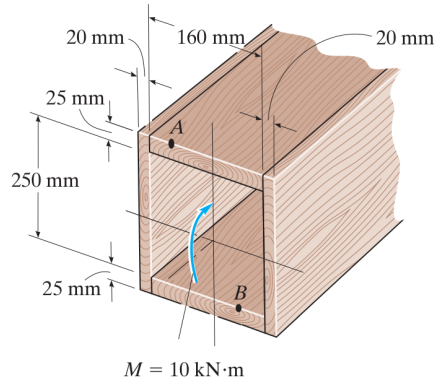

2. The shaft is supported by smooth journal bearings at A and B that only exert vertical reactions on the shaft. Determine its smallest diameter d if the allowable bending stress is $\sigma_{\text{allow}} = 180 \text{ MPa}$. $[86.3 \text{ mm}]$

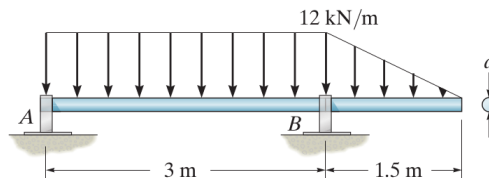

3. Two designs for a beam are to be considered. Determine which one will support a moment of $M = 150 \text{ kN}\cdot\text{m}$ with the least amount of bending stress. What is that stress? $[\text{Design (b)}; \sigma_{\text{min}} = 74.7 \text{ MPa}]$

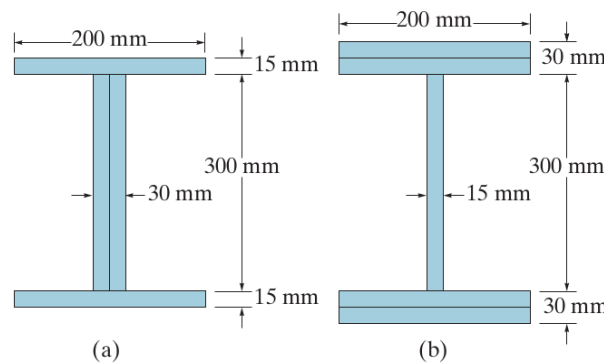

4. If the beam is subjected to an internal moment of $M = 3 \text{ kN}\cdot\text{m}$, determine the maximum tensile and compressive stress in the beam. Also, sketch the bending stress distribution on the cross section. $[\sigma_{\max,c} = 13 \text{ MPa}, \sigma_{\max,t} = 9.5 \text{ MPa}]$

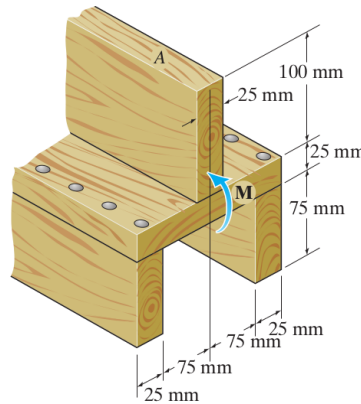

5. If the beam is subjected to an internal moment of $M = 100 \text{ kN}\cdot\text{m}$, determine the bending stress developed at points A, B, and C. $[\sigma_A = 122 \text{ MPa (C)}, \sigma_B = 51.1 \text{ MPa (T)}, \sigma_C = 35.4 \text{ MPa (T)}]$

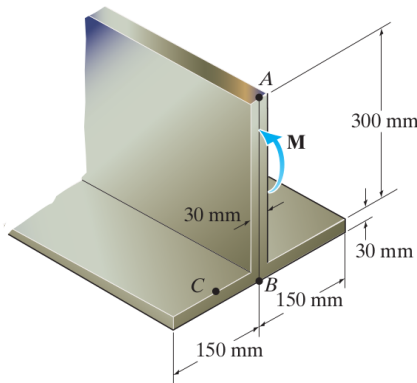

6. The shaft is supported by a smooth thrust bearing at A and a smooth journal bearing at C. If the material has an allowable bending stress of $\sigma_{\text{allow}} = 168 \text{ MPa}$, determine the required minimum diameter d of the shaft to the nearest mm. $[75 \text{ mm}]$

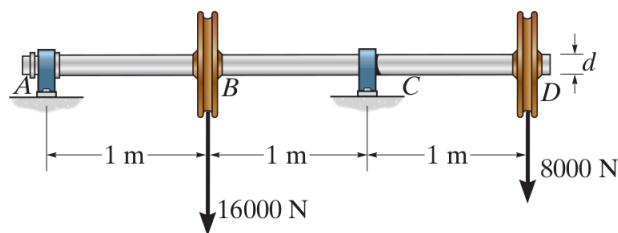

7. A log that is 0.6 m in diameter is to be cut into a rectangular section for use as a simply supported beam. If the allowable bending stress for the wood is $\sigma_{\text{allow}} = 56 \text{ MPa}$, determine the required width b and height h of the beam that will support the largest load possible. What is this load? [$b = 346.41 \text{ mm}$, $h = 490 \text{ mm}$, $P = 647 \text{ kN}$]

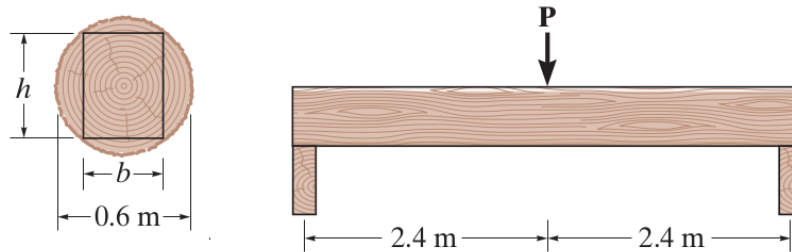

8. Straight rods of 6 mm diameter and 30 m length are stored by coiling the rods inside a drum of 1.25 m inside diameter. Assuming that the yield strength is not exceeded, determine the maximum stress in a coiled rod and the corresponding bending moment in the rod. Use $E = 200 \text{ GPa}$. [965 MPa , $20.5 \text{ N}\cdot\text{m}$]

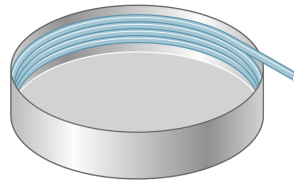

9. A copper strip and an aluminium strip are bonded together to form the composite beam shown. Knowing that the beam is bent about a horizontal axis by a couple of moment $M = 35 \text{ N}\cdot\text{m}$, determine the maximum stress in the aluminium strip and the copper strip. The Young's modulus of copper is 105 GPa and that of aluminium is 75 GPa. [-56.0 MPa , 68.4 MPa]

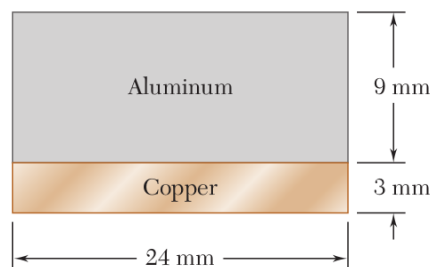

10. The reinforced concrete beam shown is subjected to a positive bending moment of 175 kN·m. Knowing that the modulus of elasticity is 25 GPa for the concrete and 200 GPa for the steel, determine the stress in the steel and the maximum stress in the concrete. [212 MPa, -15.59 MPa]

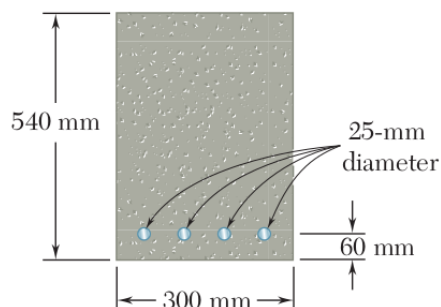

11. The composite beam shown is formed by bonding together brass rod and an aluminium rod of semicircular cross sections. The modulus of elasticity is 100 GPa for the brass and 70 GPa for the aluminium. Knowing that the composite beam is bent about a horizontal axis by a moment of 900 N·m, determine the maximum stress in the brass and in the aluminium. [-159.4 MPa, 129.7 MPa]

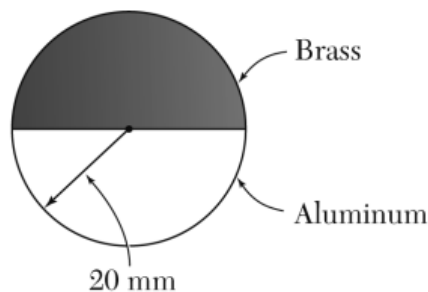

12. The rectangular beam shown is made of a plastic for which the value of the modulus of elasticity in tension is one-half of its value in compression. For a bending moment $M = 600 \text{ N}\cdot\text{m}$, determine the maximum tensile and compressive stresses. [6.15 MPa, -8.69 MPa]

