

MECHANICS (ME10001)

Tutorial 8: Concept of Stress and Strain - III

1. A cylindrical shell 3m long has 1m diameter and 15 mm thickness. Calculate the circumferential stress and longitudinal stresses induced and the change in diameter, if subjected to an internal pressure of 1.5MPa. $E=200\text{GPa}$ and $\nu=0.3$.
2. A cylindrical tank of diameter $d=2$ m has a wall thickness $t=10$ mm. What can be the maximum height of water in the tank if the circumferential stress in the wall is not to exceed 10 MPa.

3. A steel penstock has a 750mm outer diameter, a 12mm wall thickness, and connects a reservoir at A with a generating station at B. Knowing that the density of water is 1000 kg/m^3 , determine the maximum normal stress and the maximum in-plane shear stress in the penstock under static conditions.

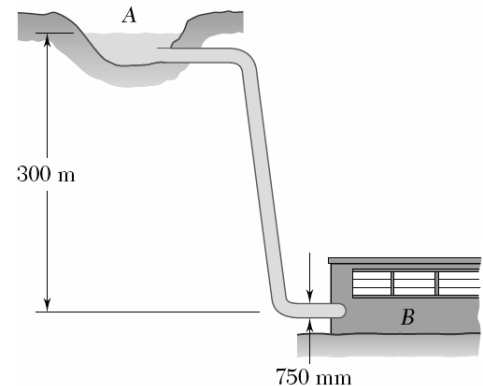

4. A steel spherical pressure vessel is being designed for a pressure of 6 MPa and an inside diameter of 600 mm. The yield stress of the steel is 400 MPa. What is the minimum required thickness t for a factor of safety against yielding of 2.5?
5. A spherical gas container having an outer diameter of 5 m and a wall thickness of 22 mm is made of steel for which $E = 200 \text{ GPa}$ and $\nu = 0.29$. Knowing that the gauge pressure in the container is increased from zero to 1.7 MPa, determine (a) the maximum normal stress in the container, (b) the corresponding increase in the diameter of the container.

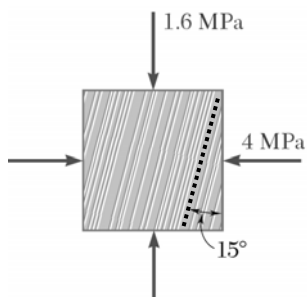

6. The grain of a wooden member forms an angle of 15° with the vertical. For the state of stress shown, determine (a) the in-plane shearing stress parallel to the grain, (b) the normal stress perpendicular to the grain.

7. Two steel plates of uniform cross section 10×80 mm are welded together as shown. Knowing that centric 100-kN forces are applied to the welded plates and that the in-plane shearing stress parallel to the weld is 30 MPa, determine (a) the angle beta, (b) the corresponding normal stress perpendicular to the weld.

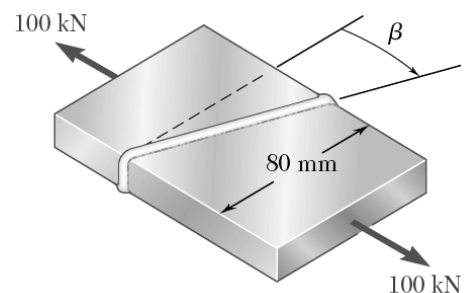

8. For the given state of stress, determine (a) orientation of the planes of principal stresses, (b) the principal stresses, (c) the orientation of the plane of maximum in-plane shearing stress (d) the maximum in-plane shearing stress, and (e) the corresponding normal stresses.

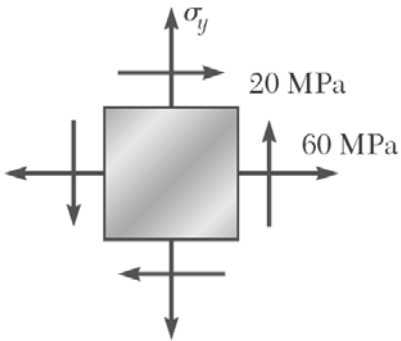

9. For the state of plane stress shown, determine the largest value of σ_y for which the maximum in-plane shearing stress is 75 MPa and the maximum tensile normal stress is equal to or less than 100 MPa.

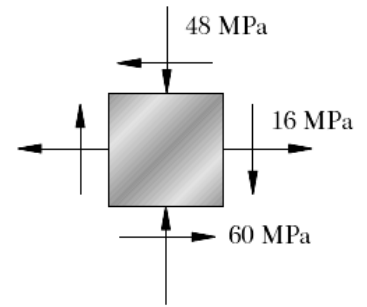

10. A single strain gage forming an angle $\beta = 18^\circ$ with a horizontal plane is used to determine the gage pressure in the cylindrical steel tank shown. The cylindrical wall of the tank is 6 mm thick, has a 600 mm inside diameter, and is made of a steel with $E = 200$ GPa and $\nu = 0.30$. Determine the pressure in the tank indicated by a strain gauge reading of 0.000280 mm/mm.

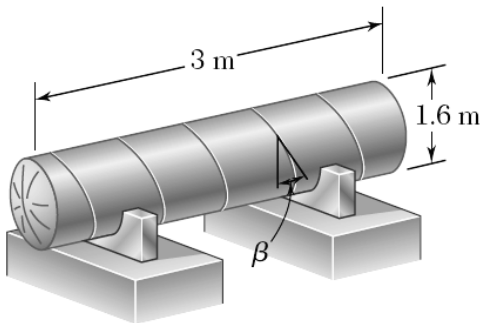
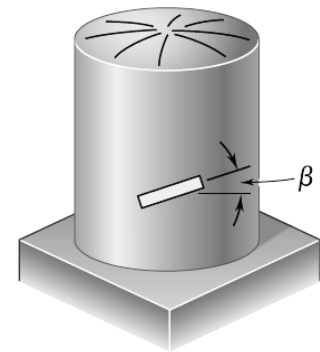

11. The pressure tank shown has 8 mm wall thickness and butt-welded seams forming an angle $\beta = 20^\circ$ with a transverse plane. For a gage pressure of 600 kPa determine, (a) the normal stress perpendicular to the weld, (b) the shearing stress parallel to the weld. Also, determine the largest allowable gauge pressure, knowing that the allowable normal stress perpendicular to the weld is 120 MPa and the allowable shearing stress parallel to the weld is 80 MPa.

12. The pressurized tank shown was fabricated by welding strips of plate along a helix forming an angle β with the axial direction. Determine the largest value of β that can be used if the normal stress perpendicular to the weld is not to be larger than 85 % of the maximum stress in the tank.

